

**Description:**

This family of Namco WFI proximity sensors are 100% solid-state switches featuring Weld Field Immunity and Short Circuit Protection.

The mechanical and electrical operating life of a sensor is largely determined by proper application and installation procedures. Please consult the factory should any questions remain after reading these instructions.

**Operating Recommendations:**

- Always operate the sensor with a resistive load that will limit the current in the circuit to levels that are within the sensor's specifications. Frequent activation of the sensor's short circuit protection could be an indication that a problem exists between the sensor and the load.
- Devices such as motors and incandescent bulbs should not be directly controlled by a proximity sensor, as their high current typically exceeds the maximum load current rating for the sensor.
- Never install a sensor such that the target or actuator will make actual contact with the sensing face. Damage to the sensor's face can cause a malfunction or failure.
- Do not attempt to modify the sensor by cutting, grinding, filing, etc.
- All sensors are completely epoxy potted, and as such do not have any serviceable parts inside. Do not remove the cover or tamper with the cable or connector.
- The user should refer to NFPA 70B, RECOMMENDED PRACTICE FOR ELECTRICAL EQUIPMENT MAINTENANCE, published by the National Fire Protection Association, for additional information.
- The Short Circuit Protection feature is designed to protect the proximity sensor and not the external circuit.
- Use of a Short Circuit Protected sensor does not eliminate the need for branch circuit fusing.
- Safety first - remove power before correcting short circuit condition.

LED Functions	10-30VDC		20-230VAC/DC 20-150VAC/DC	
	Green	Yellow	Red	Green
Power Off	Off	Off	Off	Off
Power On Load De-energized	On	Off	On	Off
Power On Load Energized	On	On	Off	On
SCP Mode Activated	Flashing		Flashing	

**\*Short Circuit Protection:**

If the sensor's output is shorted, the Short Circuit Protection (SCP) feature will be activated. SCP is designed to protect the sensor's internal circuitry against damage caused by accidental short circuits. SCP is not intended for protection of external control circuits; the use of short-circuit-protected sensors does not eliminate the need for appropriate branch circuit fusing.

In products with latching-type SCP, the occurrence of a short circuit condition will cause the sensor output to immediately turn off and flash both "TARGET" and "READY" indicators continuously. This state will be maintained (latched) until the short circuit condition is removed. Cycling power will reset the sensor to normal operation.

In products with non-latching-type (self-resetting) SCP, the occurrence of a short circuit condition will cause the sensor output to immediately turn off and flash both "TARGET" and "READY" indicators as long as the shorted condition is present. This state will automatically self-reset within 120ms after removal of the short circuit condition.

**WARNING:**

A SWITCH IN A PROTECTIVE INTERLOCKING CIRCUIT SHOULD BE USED WITH AT LEAST ONE OTHER DEVICE THAT WILL PROVIDE A REDUNDANT PROTECTIVE FUNCTION, AND THE CIRCUIT SHOULD BE SO ARRANGED THAT EITHER DEVICE WILL INTERRUPT THE INTENDED OPERATION OF THE CONTROLLED EQUIPMENT. (PROPOSED NEMA ICS 2-225.95 St'd.)

SERVICING ENERGIZED INDUSTRIAL CONTROL EQUIPMENT CAN BE HAZARDOUS. SEVERE INJURY OR DEATH CAN RESULT FROM ELECTRICAL SHOCK, BURN OR UNINTENDED ACTUATION OF CONTROLLED EQUIPMENT.

RECOMMENDED PRACTICE IS TO DISCONNECT AND LOCK OUT CONTROL EQUIPMENT FROM POWER SOURCES, AND DISCHARGE STORED ENERGY IN CAPACITORS, IF PRESENT. IF IT IS NECESSARY TO WORK IN THE VICINITY OF ENERGIZED EQUIPMENT, ONLY QUALIFIED PERSONNEL SHOULD BE PERMITTED TO PERFORM SUCH WORK, USING ALL APPLICABLE SAFETY PRACTICES AND PROTECTIVE EQUIPMENT.

Supply Voltage	10-30VDC	20-230VAC/DC	20-150VAC/DC
Voltage Drop	<2.5V @ 200mA <2.0V @ 100mA	<10V	<10V
Max. Load Current @ -25°C to +70°C	200mA	500mA	200mA
Inrush Current (RMS 1 cycle)	—	3A	1.5A
Leakage Current	10µA	*1.7 (4.5)mA	*1.7 (4.5)mA
Response Time**	30ms/0.5 sec.		
Power-up Time	35ms to 45ms/70ms (FlatPak only)		
Max. Switching Frequency	15Hz		
Ambient Temp. Range	-25°C to +70°C		

\* Refer to product label to verify leakage current

\*\* Products with part numbers ending in "-XXXX5" incorporate a "0.5 second guaranteed on-time" feature:

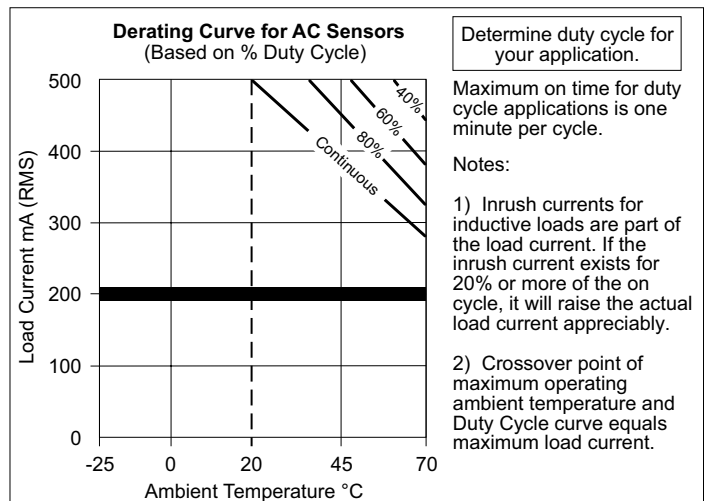

**50mm Dimensions**

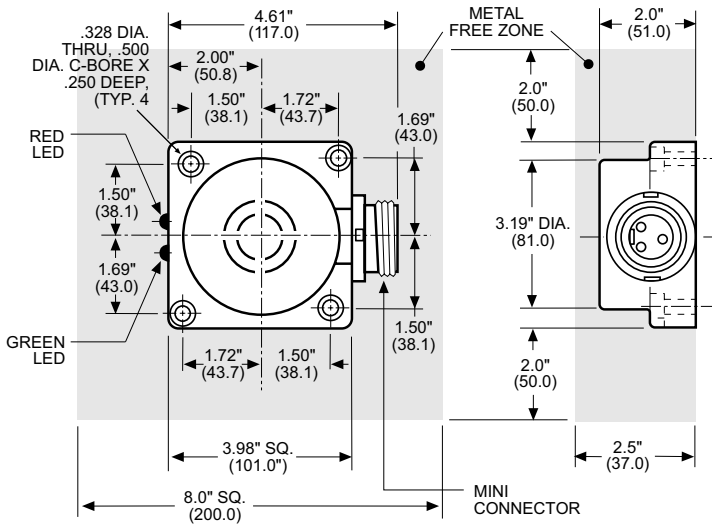

**25mm Dimensions**

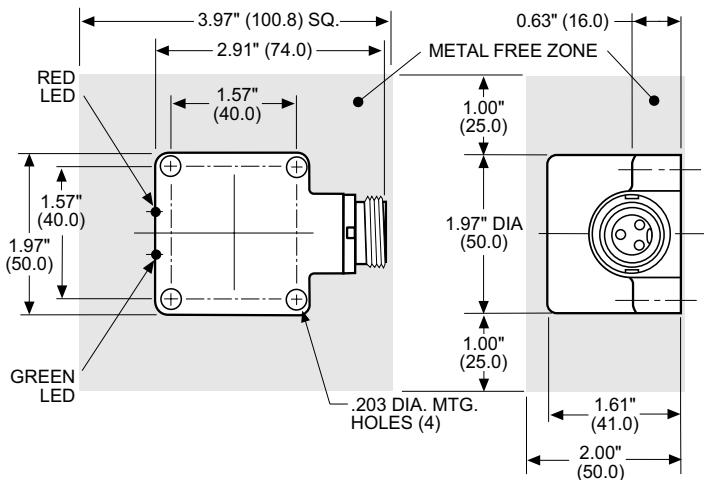

**FlatPak Dimensions**

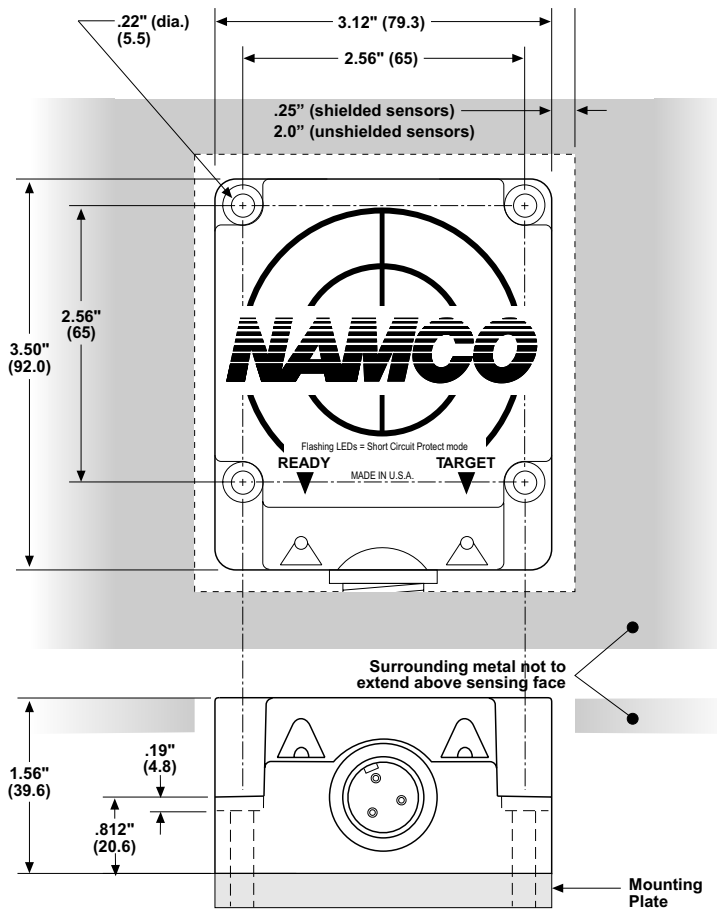

**Cable Cautions**

- Cable should never be in tension
- Always dress cable for sufficient slack

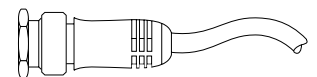

**Wiring Diagrams**

**Mini Connector (2-wire AC/DC N.O.)**

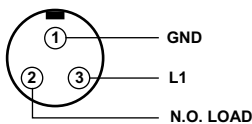

**Mini Connector (3-wire DC N.O.)**

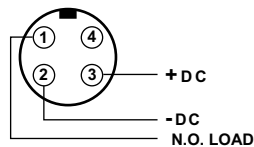

**Micro Connector (2-wire AC/DC N.O.)**

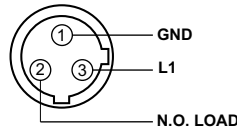

**Euro Connector (3-wire DC N.O.)**

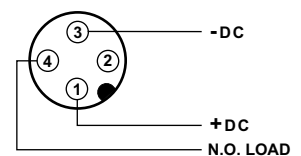

**Cable (2-wire AC/DC N.O.)**

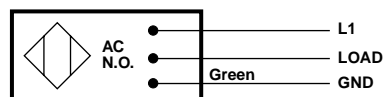

**Cable (3-wire DC N.O.)**



2013 West Meeting Street • Lancaster, SC 29720 • Technical Assistance: 1-800-NAMTECH

GmbH • Mittelfeld 10 • D-25379 Herzhorn • Tel +49-4124-9359 0 • Fax +49-4124-9359 15

© 2002 Namco | www.namcocontrols.com | EEIS26-J (IO500-30010) 7/2002

The AC products covered in this publication embody an invention protected by U.S. patents number 4571501.